

A Channel Model Proposal for Indoor Power Line Communications

F.J. Cañete, J.A. Cortés, L. Díez and J.T. Entrambasaguas
Dpt. Ingeniería de Comunicaciones, Universidad de Málaga.
`francis@ic.uma.es`

January 14, 2011

Abstract

In this paper, a channel model for broadband indoor Power Line Communications (PLC) is presented and discussed. The modeling approach is based on the physical structure of the electrical networks inside homes and small offices. The structure has been simplified to derive a parametric model that still preserves the essential behavior of these channels in the HF band (up to 30 MHz). The model provides realistic channels by setting values to a reduced number of physical parameters. In addition, statistical distributions for such parameters that allow generating ensembles of random channels are suggested. The validity of the generated channels is assessed by comparing their behavior to the one of channels measured at several indoor power networks. Hence, this model can be employed to estimate the performance of transmission techniques on PLC channels, to aid in the design of PLC systems or to make prototypes conformance tests.

1 Introduction

The topic of this work is the use of low voltage distribution lines inside buildings as a transmission medium for broadband communications. This kind of technology is known as PLC and it is not only a promising solution for home networking but also a technical reality [1]. In particular, a channel model that includes the most important physical characteristics of these channels is presented. The proposal aims to serve as a reference channel model that helps in the design and development of PLC communication systems.

The most important advantage of PLC technology is that power lines are wherever a computer or a multimedia system is being used. This is usually true even for laptops: most of the time they are plugged to the power-grid because of battery limitations. Therefore, in practice, the mobility that PLC technology offers is really close to the one of wireless technologies. Nowadays, there exist several commercial alliances, like Homeplug or UPA (Universal Powerline Association), which support PLC technologies and offer modems with bit-rates of tens of Mbps at normal conditions. Recently, two international standards for PLC have been released: the IEEE P1901 "Standard for Broadband over Power Line Networks: Medium Access Control and Physical Layer Specifications" and the ITU-T Recommendation G.9960 "Next generation

wireline based home networking transceivers”, which specifies the Physical Layer and the architecture of the so-called G.hn Recommendation. It is expected that these two standards will help to definitely consolidate PLC technology in the market.

However, PLC channels modeling represents a challenging task, to a great extent due to the fact that power lines were not designed to convey information signals, but energy. This kind of channels, when used in the high frequency band (some tens of megahertz), exhibit a behavior far from the expected in a wired network [2]. On the one hand, propagation phenomena were not taken into account when deploying the wires, what leads to an important signal distortion caused by the multi-path effect. On the other hand, the underlying presence of the high-level mains voltage obliges to consider some non-linear effects in the devices connected to the network. Fortunately, such non-linear behavior can be simplified to obtain tractable models based on linear time-varying systems [3].

The paper is organized as follows. In the next two sections, a brief review of PLC channels properties and the models proposed so far is given. Afterwards, a new proposal of channel model is explained and some examples of its results are presented in the fourth section. Subsequently, a channel generator, constructed according to the model principles and available at [4], is described and is used to validate the model in the fifth and sixth sections, respectively. Finally, some conclusions are summarized in the last section.

2 Review of PLC channels characteristics

Indoor power lines structure comprises many cables interconnected in a tree-like manner and deployed from the mains panel to the sockets. Unfortunately, there exists no impedance matching at the different discontinuities: both at the junctions of cables and the sockets, where appliances are plugged in. This creates many signal reflections and multi-path propagation phenomena that leads to a significant **linear distortion**. These effects are very dependent on the power network under study, the cables layout and the type of devices or appliances connected to them. Although the power grid deployment practices in different parts of the world are relevant, even in a particular network, the selection of the sockets to connect the transmitter and receiver has a strong influence on the final channel response. PLC channel distortion takes a twofold form: a high attenuation, for the short distances involved, exceeding 50 dB in some links; and also the presence of many deep notches at certain frequencies, in which the attenuation increases abruptly by up to 30 dB [2]. Besides, some frequency bands are forbidden for transmission by electromagnetic compatibility regulations to avoid interference to other radio systems. Therefore, the useful band for PLC systems is not contiguous.

Apart from the aforementioned impairments, indoor PLC channels present also a **time variation** caused by the functioning of the connected appliances and devices. Some of such loads contain non-linear elements like thyristors that are commuting synchronously with the mains voltage period, others do not commute but change continuously. These changes imply a variation of the loads impedance along the mains period. For instance, low-energy bulbs (compact fluorescent lamps) exhibit this kind of behavior. Due to this effect, the overall channel can be represented as a linear periodically time-varying (LPTV) system synchronized with the mains. Fortunately, measurements reveal that the channel can be consider as under-spread, because its coherence time (the interval in which a system can be treated as LTI, linear time invariant) is much larger than the effective length of its impulse response (hundreds vs microseconds) [3].

Regarding the **noise** scenario, in PLC channels a great variety of components can be found in the band of interest (approximately up to 30 MHz) [5]. Some can be considered stationary, although clearly non-white, others can be modeled as cyclostationary, synchronized with the mains voltage, and perhaps the most harmful ones have an impulsive character. Some of the noise components are also very selective in frequency, what, along with the presence of narrow-band radio interference, results in a non-homogeneous signal to noise ratio at the receiver [6].

3 Review of PLC channel modeling

There are basically two ways to tackle the problem of modeling a communication channel: trying to characterize its external behavior or its physical structure. In the first approach, the behavioral modeling, high-level parameters of the channel are given. This has been the case, for instance, of the propagation models for GSM (Global System for Mobile Communication) channels: impulse responses with a limited number of echoes. In such kind of models, the parameters values are usually derived from the statistical analysis of extensive measurement campaigns. The second alternative consists in a physical model with low-level parameters that fits the main channel features. This has been done, for example, in the DSL (Digital Subscriber Line) environment for conformance testing. To this end, some test loops were defined with a selection of cables physical characteristics and their configuration, upon which, transmission systems performance can be assessed.

In the case of indoor PLC channels, to reach a good behavioral model, i.e. the first approach, is quite difficult because the parameter values are set from measurement results. As the wiring practices are different in many sites around the world, measurements from every location would be required. Some efforts in this way have been made. In [7], the authors put the focus on the outdoor part of the low-voltage power grid (used as the access network, which is another application of PLC) and, according to statistics computed from a set of measured links, estimate the parameters of an echoes model for the channel response. However, the results are not directly applicable to indoor channels, e.g. a larger number of taps is necessary, and no procedure to generate random channels is provided. In [8], statistical distributions for the model parameters in [7] are proposed to get such a channel generator. Nevertheless, there is neither a physical basis for the parameters selection nor measurements that supports it. In [9], a valuable discussion on the topic is given and a simple statistical model for a two-tap impulse response is explained. Such a simple model can be useful for assessing some systems general performance but does not provide channel responses realistic enough to help in physical layer systems design. For instance, the frequency responses exhibit a symmetry that does not represent adequately the non-homogeneous conditions of PLC channels in the whole bandwidth. Hence, it does not help to evaluate techniques for multi-carrier systems like channel estimation, practical bit-loading with tone-grouping, etc. In addition, it does not permit to estimate realistically the inter-symbol and inter-carrier interference that a signal experiences when traversing the channel.

Alternatively, in PLC channels, it is also a hard task to define structural models based on the physical network parameters, the second approach, because of the many components to be considered. There are some works in which deterministic models based on transmission line theory are presented, e.g. [10, 11]. Also in [12], a procedure to generate random PLC network topologies is discussed, but the loads model is too simplistic and the results are not statistically

validated with measurements (for instance, the generated channels exhibit a lower delay spread than the observed one).

Finally, all the referred works, but [9], only consider an LTI response for the PLC channel, disregarding its time-varying nature, when the most accurate model for these channels is an LPTV system, as demonstrated in [3]. However, as the channels are under-spread, a slow variation approximation can be assumed: the channel dynamics can be modeled with a series of LTI systems, whose responses represent snapshots of the LPTV response that repeats periodically during a mains period. In other words, the mains period is divided in a set of invariance intervals in which the channel is considered LTI. The responses of such LTI channels are naturally correlated, what can be obtained with a structural modeling ¹.

4 Channel Model Proposal

The difficulties discussed in the previous section discourage from adopting a pure deterministic approach for power line networks modeling. Basically, the unknowns about the wiring topology and the incomplete characterization of all devices in a network are enough reasons to discard it. Nor a statistical modeling at a behavioral level is the best option. This proposal can be considered as an hybrid strategy: it allows the generation of realistic channel realizations but using structural parameters instead of behavioral ones. The objective is to use a simplified topology and loads models with few parameters, from which to derive channel responses in a deterministic way. If the structural model and the parameter values are physically meaningful, the results will have the expected behavior of actual channels, in a statistical sense. This way, the parameter values can be chosen straightforwardly according to some physical considerations of the power networks under analysis.

4.1 Structural modeling principles

The common practice in PLC systems is to connect the transmitter and receiver equipment to the power grid at any socket by means of coupling circuits. These couplers protect them from the mains voltage and allow transmitting the communication signal. They are essentially filters and baluns that use differential transmission mode between two wires, usually line and neutral. Although, in the power network, there is a third conductor, the protection ground, in our modeling its influence is disregarded ².

The transmitter can be modeled by its Thèvenin equivalent circuit and the receiver by a load impedance. The wires of the indoor power grid and the remaining sockets can be modeled as the interconnection of multiple transmission lines with impedance terminations according to the general characteristics of common appliances and devices.

¹In this section, only a concise summary of the status of PLC channel modeling has been presented. A more detailed discussion can be found in [1].

²The influence of the ground conductor on the channel response is more important when the ground and neutral conductors are connected together or 'bonded' at the service panel [11]. However, this is not a common practice outside the United States as this bonding is often made at the distribution transformer, i.e. far apart from the indoor power network.

4.2 Network layout

The simplified network layout proposed in this work can be observed in Fig.1. It comprises just seven line sections and five terminations (sockets), two of them for transmitter and receiver. From the main path between transmitter and receiver, three stubs or 'bridged taps' are deployed, at the end of which load impedances are located. This configuration has been selected among others under the premise of being as simple as possible, but also offering a reasonable fit to the actual channels behavior. As a result, the network parameters to be set are only the seven line lengths: L_i ($i \in \{1, 2, 3, 4\}$) and S_i ($i \in \{1, 2, 3\}$).

The electromagnetic model for the transmission line is the two-parallel wires. From this structure, and taking data from typical electrical cables manufacturers, it is possible to derive the transmission line parameters R, L, G and C (respectively: resistance, inductance, conductance and capacitance per unit length) or γ and Z_0 (respectively: propagation constant and characteristic impedance).

4.3 Loads model

The adopted model for the loads is a subset of impedance functions that can be selective in frequency and time. After measuring many electrical appliances [3], the observed behavior can be classified into three groups: approximately constant impedances (a not very common case), time-invariant but frequency-selective impedances and time-varying and frequency-selective impedances.

For the **constant impedances**, reasonable values are $\{5, 50, 150, 1000, \infty\}\Omega$. They represent, respectively: low, RF standard, similar to transmission line Z_0 , high and open circuit impedances.

For the **frequency-selective impedances** an adequate model is a parallel RLC resonant circuit, whose impedance can be described as,

$$Z(\omega) = \frac{R}{1 + jQ\left(\frac{\omega}{\omega_0} - \frac{\omega_0}{\omega}\right)} \quad (1)$$

It contains three parameters: R , resistance at resonance; ω_0 , resonance angular frequency; and Q , quality factor (that determines selectivity). In Fig.2 (a), an example of such an impedance is shown.

The appliances connected to the power grid that present **time-varying impedances** can be classified in two groups as well. The first one corresponds to impedances with a commuted behavior, between two values Z_A and Z_B , synchronous with the mains voltage period T_0 . These impedance values can be frequency selective. The transition between them can be considered ideal for the sake of simplicity ³. As shown in Fig.2 (b), the parameters describing this time variation are the state duration, T , and the delay with respect to the mains voltage zero-crossing, D . For instance, some low-energy lamps could be put in this group.

The second group corresponds to a more 'harmonic' impedance variation along the mains

³These transitions are much shorter than the mains period. When simulating PLC systems, transitions can be considered instantaneous between two consecutive symbols. Actually, the symbol duration is usually orders of magnitude below channel coherence time.

period that can be modeled as,

$$Z(\omega, t) = Z_A(\omega) + Z_B(\omega) \left| \sin\left(\frac{2\pi}{T_0}t + \phi\right) \right|; \quad 0 \leq t \leq T_0 \quad (2)$$

This function contains a rectified sinusoid synchronized with the mains voltage, as depicted in Fig.2 (b). It has three parameters: the offset impedance, Z_A , the amplitude of the variation, Z_B , and a phase term ϕ , which serves to reference the variation with respect to the mains voltage zero-crossing. There are many small appliances whose behavior can be included in this group.

Notice that both kinds of impedance variations exhibit a periodicity related to double the mains frequency, i.e. to the absolute value of mains voltage, which corresponds to the most common observed behavior.

4.4 Channel response estimation

The model allows generating both LTI and LPTV channels responses. **LTI channels** are calculated by means of a synthesis in the frequency domain. For this purpose, the layout given in Fig.1 is represented by the interconnection of multiple transmission lines. Then, according to the transmission line theory, each section of line is modeled as a two-port network, characterized by its ABCD parameters matrix. Finally, the input-output relation of the system, i.e. the frequency response, can be obtained by matrices manipulation. It comprises the following steps:

1. Calculate the equivalent complex impedances at the beginning of each of the bridged-taps, by 'moving' the loads (using the impedance translation property of transmission lines).
2. Calculate the ABCD matrices for each of these equivalent impedances and for each of the transmission line sections between the transmitter and the receiver. The result represents a set of two-ports that have a series connection.
3. Calculate the ABCD matrix of the whole network by multiplying the previous matrices.
4. Calculate the channel frequency response, by analyzing the final two-port and the transmitter and receiver loads.

The above steps are applied at each frequency point in the band of interest. In order to guarantee a correct sampling of the response in the frequency domain, the frequency spacing must be adequately selected, below the channel coherence bandwidth. Measurements indicate that this coherence bandwidth is in the order of 200 kHz (as shown later in Fig. 4 (b)).

For **LPTV channels** generation, also a correct sampling of the channel time variation is required. Since the channel is under-spread, it can be represented by the response of an LTI system during an invariance interval shorter than the channel coherence time. Measurements indicate that the average PLC indoor channel coherence time is over 600 μ s [3]. Considering that a mains period is 20 ms in Europe (with 50 Hz mains frequency); or 16.6 ms, in other parts of the world (with 60 Hz), a number of 50 invariance intervals in a mains period is enough (this results in intervals of 400 μ s). Hence, LPTV channels are represented by the responses of a periodical series of LTI systems. The selection of an integer number of intervals in a mains period guarantees the synchronization of invariance intervals in successive mains periods.

5 Channels generation

The model presented so far permits to generate PLC channels in an twofold way. Firstly, the parameter values in the model can be manually fixed to give rise, for instance, to reference channels with best, medium and worst conditions. Secondly, they can be generated at random to create representative channels in a statistical sense. In the following, the latter alternative is addressed, by proposing parameters values, or ranges, based on many channel and load measurements and on some intuitive decisions from the physics of the problem.

We suggest the following set of parameters for **LTI channels** generation in the frequency band up to 30 MHz:

- Discrete-frequency resolution: $N=2048$ points in the positive axis, the resolution is 14 kHz.
- Transmitter and receiver (Z_G and Z_L): constant impedances of 50Ω .
- Cable types: chosen at random, with uniform distribution, among the ones in table 1. Values for R, L, G and C (per unit length) are estimated for different cable sections⁴. In the calculations, a non-homogeneous dielectric constant has been considered to include the effect of the combination of PVC (Polyvinyl chloride) and air between the wires.
- Line sections lengths (L_i and S_i): chosen at random, with uniform distribution between 0.5 and 50 m.
- Loads (Z_1, Z_2 and Z_3): frequency selective function impedances, chosen at random with the following parameters,

Resistance, $R \in \{200, 1800\}\Omega$ with a uniform distribution.

Resonant frequency, $\omega_0/2\pi \in \{2, 28\}$ MHz with a uniform distribution.

Q factor, $Q \in \{5, 25\}$ with a uniform distribution.

A uniform distribution has been selected for the parameters generation because it is the probability density function that presents the highest statistical dispersion in a limited range.

For **LPTV channels** generation, some of the loads must be time-varying. In the proposal, only one of the three loads is considered time-varying, for the sake of simplicity. Thus, the resultant channel response will exhibit a commuted or harmonic time variation, depending on the choice. The proposed set of parameters are:

- Discrete-time resolution: $M = 50$ invariance intervals in a mains cycle for a resolution of $400\mu s$.
- Loads (Z_1, Z_2 and Z_3): two of them with frequency selective function impedances (as described before) plus one with a time-varying impedance. In case a *commuted variation* is desired, the following parameters applied,

Z_B also a frequency selective function impedance, with parameters R, ω_0, Q chosen at random.

⁴A correction factor ℓ is included in the estimation of $G(S/m)$. The reason for this will be explained in section 6.

$$Z_A = Z_B \cdot 0.5.$$

T , in discrete-time, with a uniform distribution between 1 and $M/4$.

D , in discrete-time, with a uniform distribution between 0 and $M/2 - T$.

To get an *harmonic variation*, the parameters values would be:

Z_B , also a frequency selective function impedance chosen at random.

$$Z_A = 50\Omega.$$

ϕ , with a uniform distribution between 0 and π rad.

A software tool for channels generation, developed using the described procedure, is available at [4]. Its performance is illustrated in Fig.3(a), where the frequency response amplitude obtained for ten LTI channels generated at random is depicted. The frequency selectivity of the result is similar to the typical of indoor PLC channels with notches distributed along the frequency band and a decay of the channel response for the higher frequencies. Also, an example of a generated time-varying channel response (of harmonic behavior) is included in Fig.6(a).

6 Channel model performance

In this section, at first, the model validity is assessed by comparing an ensemble of random channels, created with the proposed channel generator, to a set of measured ones. Two tests have been carried out. The first one is oriented to study parameters related to the frequency selectivity and the second one is to analyze parameters related to the time variation. Afterwards, some remarks about the usefulness of the model are discussed.

6.1 LTI behavior validation

In order to verify the model performance, 500 random channels have been generated and compared to a set of more than 200 channels measured at different premises in Spain. The comparison is made by extracting statistical measures of some behavioral parameters. The model covers a frequency band up to 30 MHz, as current PLC modems employ such a frequency band, and because our available loads characterization is for such band. Measurements in wider bands indicate that the channels behave similarly although the coherence bandwidth is larger, so the model would be applicable but updating the parameters values.

The most important characteristics of an LTI channel are the attenuation and the frequency selectivity (or equivalently the time dispersion). The latter is usually evaluated by means of three parameters: the coherence bandwidth, the delay spread and the effective impulse response length.

In order to test the **attenuation** of the channels provided by the model, the mean amplitude (in dB) of their frequency response is calculated. Fig.3(b) depicts the estimated CDF (cumulative distribution function) of the generated and measured channels. There exists a reasonable correspondence between both distributions, but there is a higher probability of facing very attenuated channels (over 50dB) or slightly attenuated channels (under 25dB) in the measured ones.

The **delay spread** is commonly defined as the root mean square (rms) value of the channel power delay profile (i.e. of the impulse response energy distribution). And the **effective length** is defined as the time interval that contains a certain percentage of the impulse response energy, being 90 % a common value in practice. It is a useful parameter for system design, for instance to define the guard interval of a multicarrier system (the most common transmission technique in PLC).

Fig.4(a) shows the estimated CDF of the delay spread (DS) and the effective length (EL) of the generated and measured channels. Generated channels exhibit less statistical dispersion than measured channels for the two parameters, as for the attenuation. This is reasonable since the modeled network topology is simpler than real ones. Thus, there is a higher probability to find very long and very short impulse responses in the set of actual channels than in the generated ones, where a fixed number of sockets is considered. However, the statistical dispersion of the distributions in the generated channels is reasonable and there is a good fit in the central percentiles part.

Whereas the delay spread and effective length are measures of the channel time dispersion, the **coherence bandwidth** (B_c) is a direct measure of the channel frequency selectivity, its counterpart in the frequency domain. The coherence bandwidth is the interval of frequencies in which the normalized autocorrelation function of the channel frequency response is over a certain value (usually set to 0.9), i.e. a bandwidth in which the channel can be approximately considered 'flat'. In Fig.4(b) the estimated CDF of B_c is plotted for the generated and measured channels. Again, the distribution has less dispersion in the generated channels but, a remarkable fit is observed.

There is no closed-form expression that relates the delay spread and B_c in PLC channels, but they have an inverse relationship, as can be seen in the scattering plot in Fig.5(a). It can be concluded that the correlation of the two parameters is basically the same for measured and generated channels.

At this point it is interesting to justify the overestimation of the cables losses, which relies to a great extent on the G parameter of the transmission line. It is accomplished by means of the factor denoted as ℓ in table 1 and whose objective is to achieve a better matching between the attenuation curves in Fig.3(b) ⁵. This modification is founded on the following reasoning. In actual indoor PLC channels, the observed attenuation is higher than expected just from the cables losses, as the involved distances are not too long. This attenuation is essentially due to multi-path, to the energy dispersion experimented by the signal as it traverses each discontinuity (the effect of cable losses are mainly visible at higher frequencies). Since in the model the number of discontinuities is much lower than in actual channels, increasing the cable losses to compensate for this has a practical sense. The time dispersion of the channel is naturally affected by both the number of discontinuities and the cable losses: it depends on the delay, amplitude and width of the echoes arriving at the receiver. Hence, there is a correlation between the delay spread and the attenuation in these channels, what confirms the measurement results reported in [9]. Fig.5(b) reveals that the model reflects this correlation in a quite approximated manner despite the introduced correction factor. Moreover, after applying some statistical tests it has been concluded that channel attenuation and delay spread of generated and measured channels exhibit the same probability distributions (although different statistical dispersion), what reinforces that the correction factor do not alter the essentials of the results.

⁵The value of ℓ has been heuristically set to five for the particular set of measurements

6.2 LPTV behavior validation

To validate the time variation of the modeled channels, 200 random channels have been created with the parameters values in section 5, half with harmonic variation and a half with commuted variation. This set of channels are compared with a set of about 50 channels measured at different homes in Spain ⁶.

The most common parameter to evaluate the time variation of a channel is the **Doppler bandwidth** (or Doppler spread). It represents the spectral broadening at the channel output when it is excited by a sinusoid. In an LPTV channel, as the system response is periodic in time, this spread appears as discrete spectral components harmonically related to the inverse of the system period, i.e. the mains frequency in PLC. A reasonable measure of the Doppler spread in this case is to calculate the largest harmonic whose magnitude is over a certain threshold [3]. The criterion in this work has been to set a threshold of 40 dB under the maximum. The estimated CDF of the Doppler bandwidth, for both the generated and the measured channels, is plotted in Fig.6(b), where it is observed that the curves matches approximately.

In PLC channels, the channel variation is mainly observed in the shape of the impulse response (and consequently in the frequency response) but not in the amount of time dispersion, i.e. delay spread or effective length. This effect is also typical in wireless channels and is very important, for instance, in multi-carrier systems, because it allows the use of a constant guard interval. This extreme has been tested also in the generated channels: in the 90% of cases the rms value of the delay spread variation along a mains period, normalized to the mean value, does not exceed 5 %. This value is practically the same as the corresponding one from measured channels.

As explained in section 2, the channel time variation is also selective in frequency, that is, some of the frequency bands in the channel response can exhibit a fading in time while other bands are mainly invariants. For instance, in half of the measured channels, the frequency response is practically time invariant in around 30 % of the considered frequencies. This behavior has been incorporated to the channel model by using frequency-selective functions for impedances Z_A and Z_B . As a result, similar percentages of time invariant frequencies are obtained in the generated channels. The Doppler bandwidth values among frequencies of the same channel response are quite diverse as well. An rms variation of about 100 % with respect to the mean value has been observed in half of the generated channels, also in measured ones.

As a final remark, it should be highlighted that the validation of the time varying nature of the generated channels is subject to the uncertainty of the proportion of actual channels that present a commuted or a harmonic behavior or even a non-significant time-varying behavior at all. This is due to the strong influence that the appliances connected at each power network have on the kind of variation.

6.3 Recommendations for using the model

The described model offers a great flexibility in the channel generation. The model parameters have been proposed from the authors expertise but, according to other network configurations, different parameter values can be chosen to create channels with different characteristics. Moreover, some parts of the model can be modified if desired, e.g. the loads model, the cables data,

⁶The number of measured channels available for the LPTV tests is smaller because the measurement procedure required to extract the time-varying behavior of the channel response is more complex and time consuming.

etc.

Specifically, an increment in the cable loss factor ℓ produces more attenuated channels and enhances the decay in frequency of the amplitude response, but reduces moderately the delay spread (so increases the coherence bandwidth). Longer bridged taps give rise to channels with a higher delay spread, whereas the attenuation is not increased significantly if the length of the main path is maintained. A reduction of the number of bridged taps (setting the length of some of them to zero) leads to better channels, with a lower attenuation and delay spread. Conversely, worse channels result by including additional bridged taps. Concerning the time-varying behavior, it can be discarded in the generated channels by using only invariant impedance functions for the loads, or enhanced by selecting more than one varying load.

Furthermore, a change in the statistical distribution of some of the physical parameters alters the probability distributions and scattering plots of the channel behavioral parameters. Particularly, instead of a unique distribution for the random lengths, uniform distributions with different ranges of values according to small, medium or large premises can be selected. Alternatively, in case some improbable channels with longer lengths are wanted, a distribution without a finite support like the Gamma distribution could be a good option. In such a case, the recommendation is to use a low 'shape parameter' value and a high 'scale parameter' value (e.g. 1.5 and 18, respectively, lead to a good fit for our set of measurements).

7 Conclusion

In this paper, a simple model for indoor PLC channels has been proposed. It is based on a bottom-up approach, in the sense that the focus is put on the physical characteristics of the channel: the network layout, the cables and the loads. The model represents a trade-off between simplicity and a good fit to indoor PLC channels behavior. It is simple enough to allow generating random channels by setting few parameters. Then the responses are derived deterministically taking into account the physical structure of power networks. A statistical analysis has been used to validate the model principles, demonstrating that the behavior of the generated channels matches, to a great extent, with the one observed in a set of measured channels.

The model covers all the common features of PLC channels: a high frequency selectivity, significant attenuation and time-varying nature. In addition, the authors provide a channel generator based on the model that can be used with a twofold functionality: a deterministic mode, in which the parameters values are manually selected, to define for example reference channels for conformance testing or to benchmark transmission techniques; and a random mode, in which statistical distributions for the parameters values are suggested to create ensembles of channels. Since the model is based on the physical channel features, its results present statistical distributions of behavioral parameters like the delay spread, the attenuation or the frequency selectivity of the time variation close to reality. The correlation observed in actual channels between some of these parameters appears also in the model results. Therefore, the proposal in this paper can be helpful to evaluate the performance of PLC channels and also to develop signal processing algorithms for PLC technology.

References

- [1] H. Ferreira, L. Lampe, J. Newbury, and T. Swart, Eds., *Power Line Communications: Theory and Applications for Narrowband and Broadband Communications over Power Lines*, Wiley, 2010. ISBN: 9780470740309.
- [2] H. Philipps, "Performance measurements of power line channels at high frequencies," in *International Symposium on Power-Line Communications and its Applications*, ISPLC 1998, Soka (Japan), pp. 229-237.
- [3] F.J. Cañete, J.A. Cortés, L. Díez, and J.T. Entrambasaguas, "Analysis of the cyclic short-term variation of indoor power-line channels," *IEEE Journal on Selected Areas in Communications*, vol.24, Jul 2006, pp. 1327-1338.
- [4] <http://www.plc.uma.es> , website of the PLC Group, Ingeniería de Comunicaciones Department, Universidad de Málaga.
- [5] M. Zimmermann and K. Dostert, "Analysis and modeling of impulsive noise in broad-band powerline communications," *IEEE Transactions on Electromagnetic Compatibility*, vol.44, n.1, Feb 2002, pp. 249-258.
- [6] J.A. Cortés, L. Díez, F.J. Cañete, J.J. Sánchez-Martínez,, "Analysis of the Indoor Broad-band Power-Line Noise Scenario," *IEEE Transactions on Electromagnetic Compatibility*, vol.52, n.4, Nov 2010, pp. 849-858.
- [7] M. Zimmermann and K. Dostert, "A multipath model for the powerline channel," *IEEE Transactions on Communications*, Apr 2002, pp. 553-559.
- [8] A. Tonello, "Wideband impulse modulation and receiver algorithms for multiuser power line communications," *EURASIP Journal on Advances in Signal Processing*, Volume 2007, Article ID 96747, 2007.
- [9] S. Galli, "A simple two-tap statistical model for the power line channel," in *International Symposium on Power-Line Communications and its Applications*, ISPLC 2010, Rio de Janeiro (Brazil), 2010.
- [10] F.J. Cañete, L. Díez, J.A. Cortés, and J.T. Entrambasaguas, "Broadband modelling of indoor power-line channels," *IEEE Transactions on Consumer Electronics*, Feb 2002, pp. 175-183.
- [11] S. Galli and T. Banwell, "A deterministic frequency-domain model for the indoor power line transfer function," *IEEE Journal on Selected Areas in Communications*, vol.24, Jul 2006, pp. 1304-1316.
- [12] T. Esmailian, F.R. Kschischang, and P. G. Gulak, "In-building power lines as high-speed communication channels: channel characterization and a test channel ensemble," *International Journal of Communication Systems*, Jun 2003, pp.381-400.

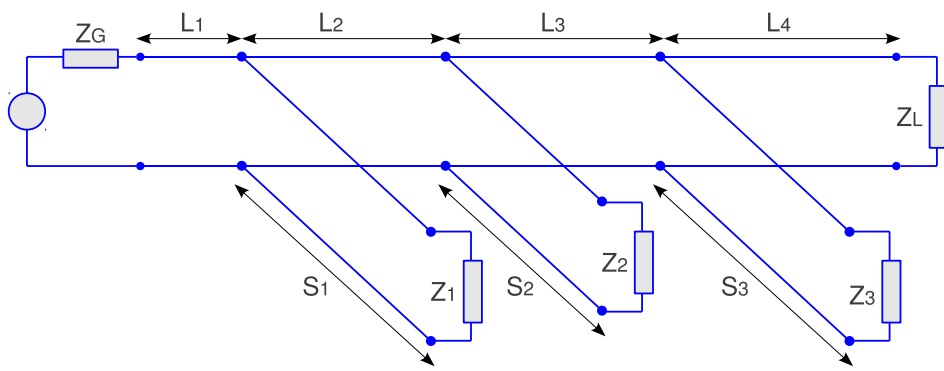

Figure 1: Proposed network topology for the model.

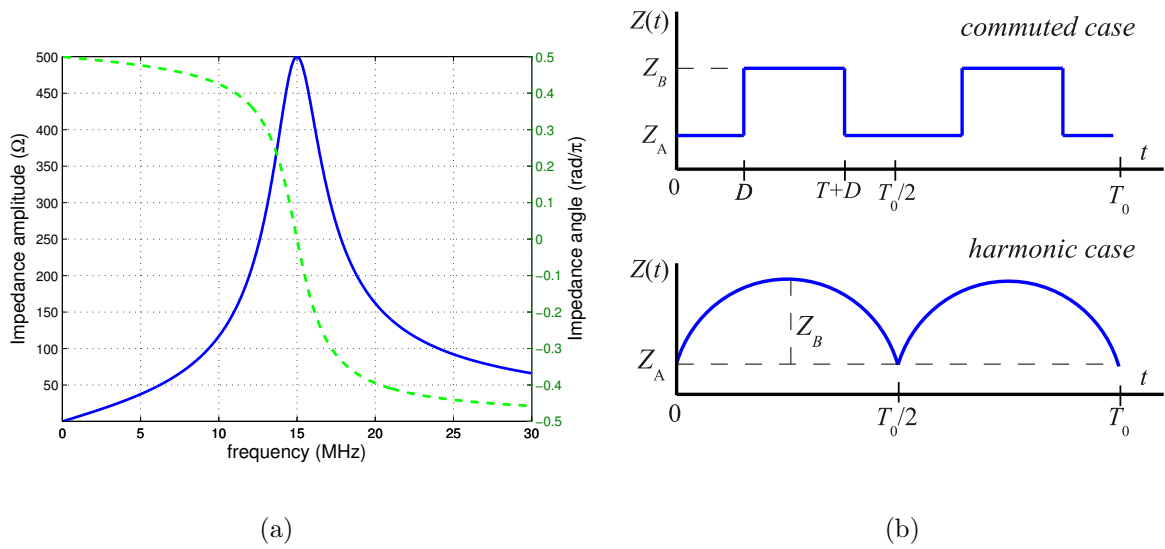
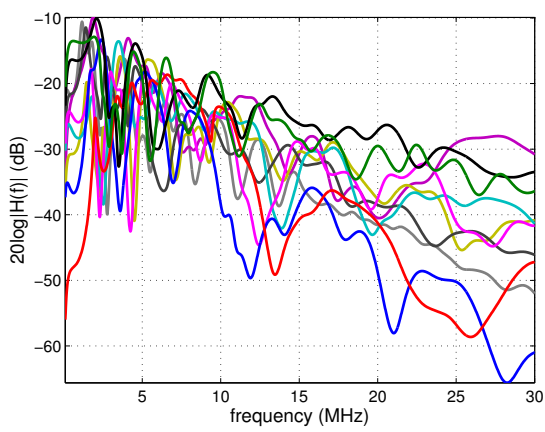

Figure 2: Impedance models: (a) an example of the frequency-selective impedance (the resonance frequency is 15MHz, the resistance is 500 Ω and the Q factor is 5); (b) diagrams of the two time-varying impedance models.

Cable type	0	1	2	3	4
section (mm ²)	1.5	2.5	4	6	10
ε_{eq}	1.45	1.52	1.56	1.73	2
$Z_0(\Omega)$	270	234	209	178	143
C (pF/m)	15	17.5	20	25	33
L (μ H/m)	1.08	0.96	0.87	0.78	0.68
R_0	12	9.34	7.55	6.25	4.98
G_0	30.9	34.7	38.4	42.5	49.3

Table 1: Characteristics of actual indoor power network cables. $R = R_0 \cdot 10^{-5} \sqrt{f}$ (Ω/m) and $G = G_0 \cdot \ell \cdot 10^{-14} \cdot 2\pi f$ (S/m).



(a)

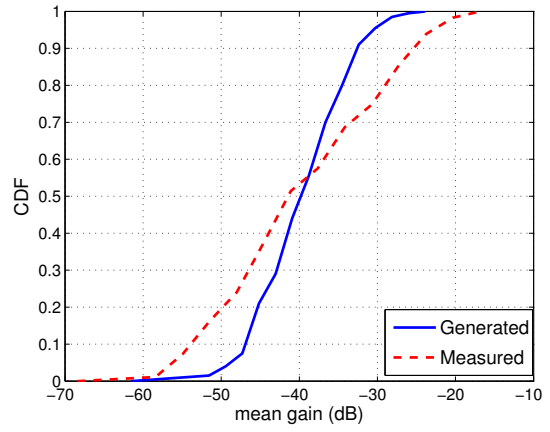

(b)

Figure 3: (a) Gain of the frequency response ($20 \log |H(f)|$) of some LTI generated channels; (b) estimated CDF of the mean gain for measured and generated channels.

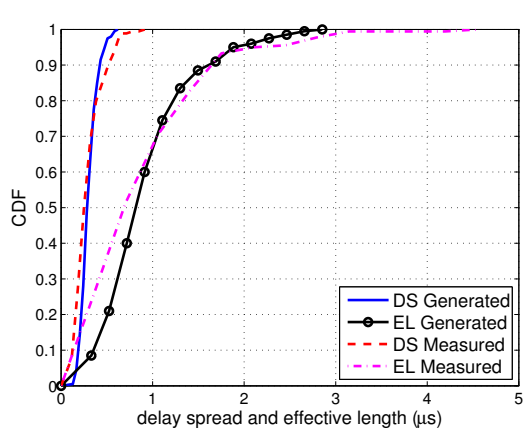

(a)

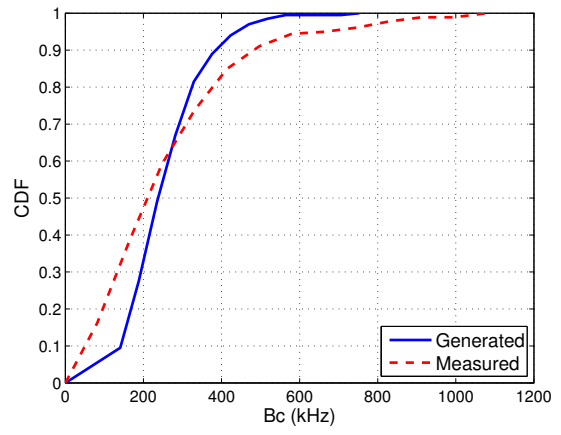

(b)

Figure 4: Comparison between measured and generated channels: estimated CDF (Cumulative Distribution Function) of the (a) delay spread and effective length of the impulse response; (b) coherence bandwidth (B_C).

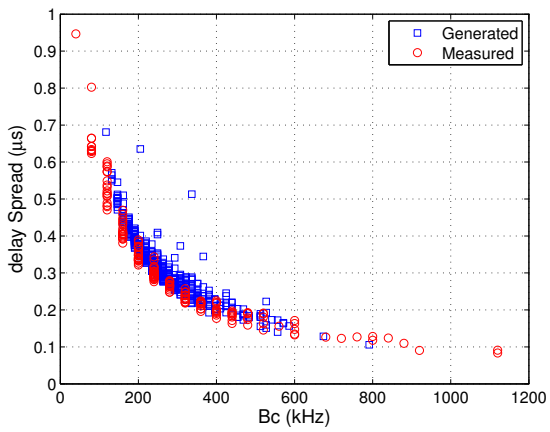

(a)

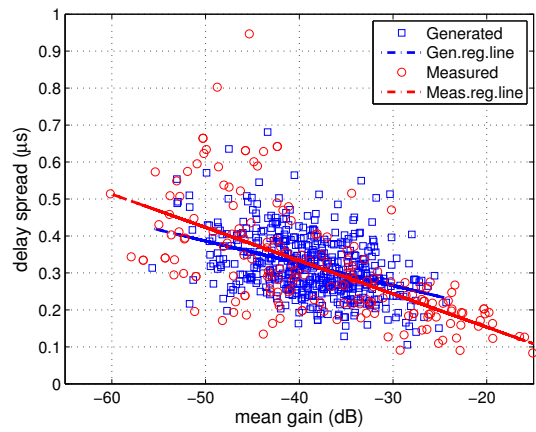

(b)

Figure 5: Comparison between measured and generated channels. Two scattering plots are given: (a) delay spread vs. coherence bandwidth ; (b) delay spread vs. mean gain (with regression lines).

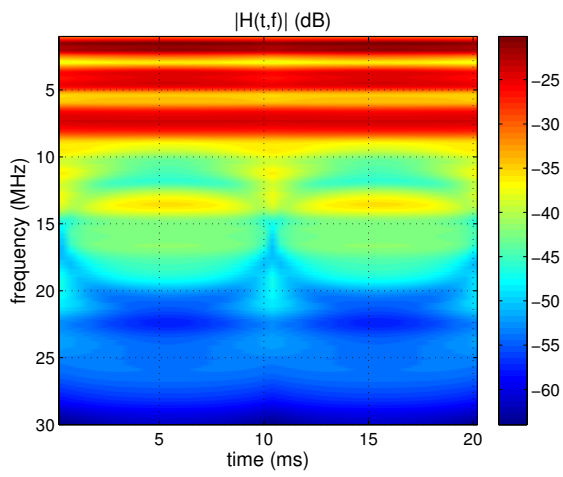

(a)

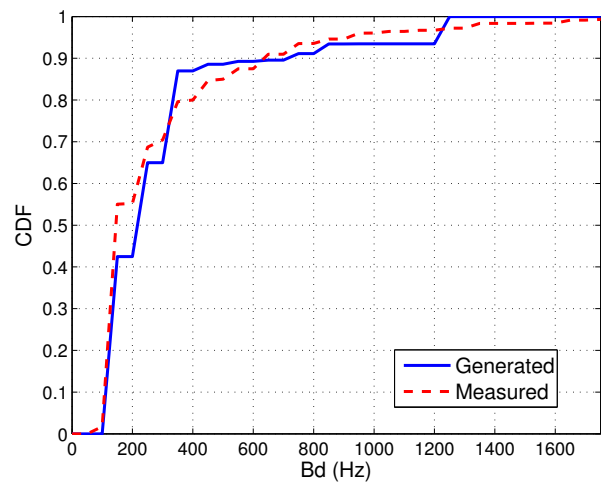

(b)

Figure 6: LPTV channels: (a) an example of generated frequency response gain; (b) estimated CDF of the Doppler bandwidth for measured and generated channels.

Biographies

Francisco Javier Cañete Corripio received the M.S. and Ph.D. degrees in telecommunication engineering in 1996 and 2004, respectively, from the University of Málaga (Spain). In 1996, he worked for the Instrument and Control department at the Empresa Nacional de Ingeniería y Tecnología (INITEC) in the design of power plants. In 1997, he worked for Alcatel España R&D department in the design of wireless local loop systems. Since 1998 he works for the Communication Engineering Department, at University of Málaga, currently as an associate professor. From 2000 to 2001, he also collaborated with the Nokia System Competence Team in Málaga. His research activity is focused on digital signal processing for digital communications and his interests include channel modeling and transmission techniques for power-line communications and wireless systems. He is member of the IEEE.

José Antonio Cortés Arrabal received the M.S. and Ph.D. degrees in telecommunication engineering in 1998 and 2007, respectively, from the University of Málaga (Spain). In 1998, he received a fellowship from Alcatel Citesa. In 1999, he worked for Alcatel España R&D. This same year he joined the Communication Engineering Department of the University of Málaga, where he is currently working as an associate professor. From 2000 to 2002, he collaborated with the Nokia System Competence Team in Málaga. His research interests include digital signal processing for communications, mainly focused on synchronization and transmission techniques for high-speed power line communications. He is member of the IEEE.

Luis Díez del Río received the M.S. and Ph.D. degrees from the Polytechnic University of Madrid, Spain, in 1989 and 1995, respectively, both in telecommunications engineering. In 1984, he joined Fujitsu-España R&D center, where he worked in the development of modems. From 1987 to 1997, he was with the Department of Signals, Systems and Radiocommunication, Polytechnic University of Madrid. Since 1997, he has been with the Communication Engineering Department, University of Málaga. His experience includes many applications of digital communications, like voice band, DSL and cable modems, satellite, mobile, and power line communications, in several technical aspects, like synchronization, adaptive signal processing, modulation, coding and multiple access.

José Tomás Entrambasaguas Muñoz received the M.S. and Ph.D. degrees, in 1975 and 1990, respectively, both from the Polytechnic University of Madrid, Spain. From 1975 to 1978, he worked at the Polytechnic University of Madrid. In 1978 he joined Fujitsu-España R&D center, where he worked in the development of packet switching systems, data transmission systems, and computer local area networks. In 1993, he joined the University of Málaga at the Communication Engineering Department, where he is currently a full professor. His current interests include digital signal processing techniques applied to digital communication and methodologies for efficient and integrated development of complex communications systems. He is member of the IEEE.