



ADuC8xx SAR EVALUATION BOARD REFERENCE GUIDE



MICROCONVERTER[®]
QUICKSTART[™] DEVELOPMENT SYSTEM

CONTENTS:**Evaluation Board Reference Guide:**

1) Evaluation Board Overview	3
2) Evaluation Board Features	4
3) External Connectors	7
4) Light Dependent Resistor Demonstration Circuit	9
5) Parts List	10

(1) EVALUATION BOARD OVERVIEW

The ADuC8xx SAR Evaluation board has the following features :

- 2 Layer PCB (4" X 5" Form Factor)
- 9V power supply/battery regulated to 5V on board
- 4 pin UART header to connect to RS232 Interface Cable
- 5 pin UART/ICE header to connect to external emulator board
- Example LDR Demonstration Circuit
- 32.768kHz Watch Crystal to drive the PLL clock OR 11.0592MHz crystal
- Reset/External Interrupt 0 Push Buttons
- Power on Reset circuit for ADuC812 (not required for other parts)
- Power Indicator/General Purpose LEDs
- Access to all ADC inputs from external header. DAC output channel buffered to external header. All device Ports and Strobes are brought out to external header pins.
- Surface Mount and Through Hole General Purpose Prototype Area

THIS DOCUMENT REFERS TO THE MICROCONVERTER SAR EVAL BOARD REV A3

NOTES :

1. All references in this document to physical orientation of components on the board are made with respect to a component side view of the board with the battery connections appearing in the top left corner of the board.
2. The board is laid out to minimize coupling between the analog and digital sections of the board. To this end, the ground plane is split with the analog section on the left hand side and a digital plane on the right hand side of the board. The regulated 5V power supply is routed directly to the digital section and is filtered before being routed into the analog section of the board.
3. The ADuC8xx can be socketed on the board using a QFP carrier adaptor and corresponding surface mount feet available from Ironwood Electronics The part numbers are CA-QFE52SB-L-Z-T-01 and SF-QFE52SB-L-01 respectively.
WEB: www.ironwoodelectronics.com
Email: info@ironwoodelectronics.com

(2) EVALUATION BOARD FEATURES

Power Supply:

Users of the QuickStart Development System should power the evaluation board using the 9V power supply provided. Connect the 9V power supply to the 2.1mm input power socket (J6). The input connector is configured as 'CENTER NEGATIVE' i.e. GND on the center pin and +9V on the outer shield.

The 9V supply is regulated via a linear voltage regulator (U2). The 5V regulator output is used to drive the digital side of the board directly. The 5V supply is also filtered and then used to supply the analog side of the board.

When on, the green LED (D2) indicates that a valid 5V supply is being driven from the regulator circuit. All active components are decoupled with 0.1uF at device supply pins to ground.

Alternatively a 9V battery can be connected to the battery header P1.

UART/RS232 Interface:

The ADuC8xx (U1) TXD and RXD lines are connected to the RS232 Interface Cable via connector (J4). The Interface Cable generates the required level shifting to allow direct connection to a PC serial port. This interface will be the main channel of interactive comms on the board. Ensure that the cable supplied is connected to the board correctly i.e. DVDD is connected to DVDD and GND is connected to GND.

Emulation Interface:

Non intrusive single pin emulation is possible with the ADuC8xx via communications on the *EA* pin. The J5 connector allows the user to connect an emulator to the ADuC8xx evaluation board. While only the *EA* and GND connections need to be made the TXD, RXD and +9V connections are provided as added features.

The TXD and RXD can be connected so that the emulator can monitor communications on the users serial port. This allows the user to easily debug the serial port. From the IDE the user can send data to the hardware serial port to mimic an external device.

The +9V connection allows the user to power the evaluation board from the emulator itself. The 9V power supply should be connected to the emulator, which passes the 9V onto the evaluation board.

Crystal Circuit:

The board can be populated with a 32.768kHz watch crystal or a MHz crystal. This crystal is connected between the XTAL1 and XTAL2 pins. The watch crystal is populated for parts with an on chip PLL the MHz crystal (11.0592MHz) is used for the other parts.

The ADuC8xx includes internal 18pF capacitors so external caps are not required for the watch crystal.

Reset/*INT0* Push Buttons:

A **RESET push button** is provided to allow the user to manually reset the part. When inserted the RESET pin of the ADuC8xx will be pulled to DV_{DD}. Because the RESET pin on the ADuC8xx is Schmidt triggered internally there is no need to use an external Schmidt trigger on this pin.

When inserted the ***INT0* push button** switch drives P3.2/*INT0* low. This can be used to pull P3.2 low or more commonly to initiate an external interrupt 0.

To enter **serial download**/debug mode the user must pull the PSEN pin low while reset is toggled. On the evaluation board serial download mode can be easily initiated by holding down the serial download push button (SW3) while inserting and releasing the reset button (SW1) as illustrated below.

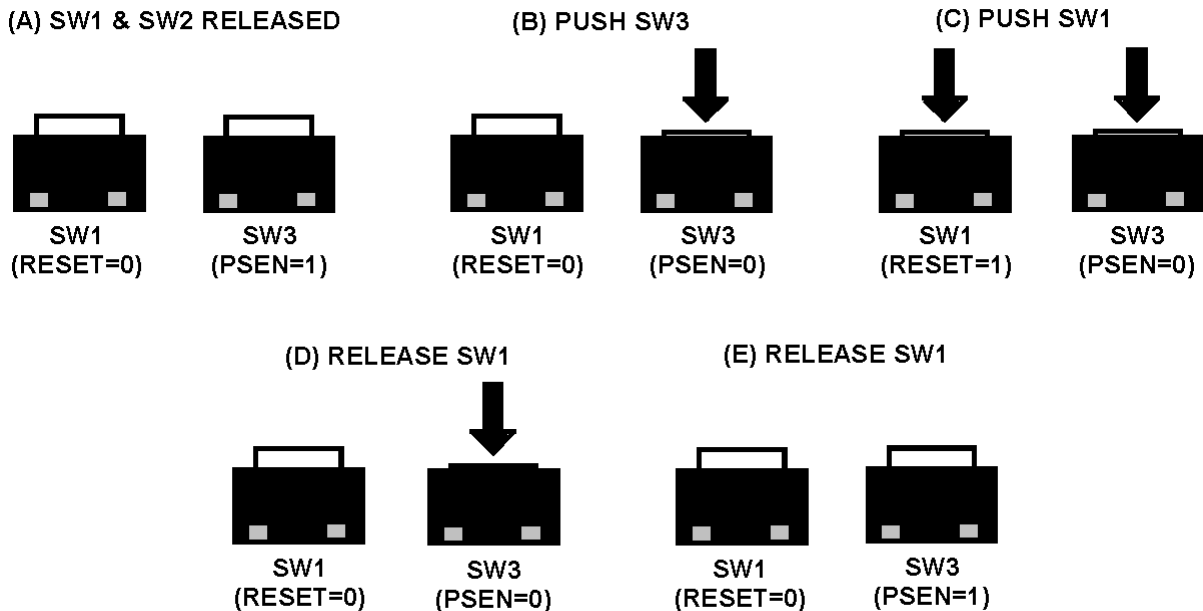

Entering Serial Download/DeBug Mode on the Evaluation Board.

Note: The ADuC812 version of the SAR board has an external power on reset circuit implemented as shown in the schematic. Zero Ohm resistors bypass this circuit in the case of all of the other SAR MicroConverter parts.

Power Indicator/General Purpose LEDs:

A green power LED (D2) is used to indicate that a sufficient supply is available on the board. A red general purpose LED (D1) is directly connected to P3.4 of the ADuC8xx. The CLR P3.4 instruction will turn the LED ON and the SETB P3.4 command will turn the LED off.

Analog I/O Connections:

All analog I/O are brought out on header J1. ADC0, ADC1, ADC2 inputs are buffered using an OP491 op amp. A resistor divider consisting of a 20kOhm resistor and a light dependant resistor is connected to ADC3 which is also buffered by the OP491. This resistor divider can be disconnected by removing the zero Ohm resistor R9.

ADC4, ADC5, ADC6 and ADC7 are not buffered. When connecting signals to these inputs be sure to follow the datasheet recommendations.

DAC0 and DAC1 outputs are both buffered externally using U3 (OP491). DAC0 enables the user to control the brightness of the LED D5. This LED can be disconnected by removing resistor R10.

The internal reference is also buffered via U3 for use externally. The reference that should be used to drive external circuits is either Vref (ADuC812) or Cref (all other SAR parts).

A detailed pin out of this connector is given in section 4.

External RAM Footprints:

Footprints and connections for an Octal type D-Latch (U6) and a 32kB SRAM (U7) are provided on the evaluation board. Recommended part numbers for these are given in the parts list.

General Purpose prototype area

General Purpose prototype areas are provided at the top and the bottom of the evaluation board for adding external components as required in the users application. As can be seen from the layout AVDD, AGND, DVDD and DGND tracks are provided in this prototype area.

(4) EXTERNAL CONNECTORS:

J1 Analog I/O Connector

The analog I/O connector J1 provides external connections for all ADC inputs, reference inputs and DAC outputs. The pinout of the connector is shown below.

Pin #	Pin Name
J1-1	ADC0
J1-2	ADC1
J1-3	ADC2
J1-4	ADC3
J1-5	ADC4
J1-6	ADC5
J1-7	ADC6
J1-8	ADC7
J1-9	DAC0
J1-10	DAC1
J1-11	Vref
J1-12	BUF Vref
J1-13	V0 (spare OP AMP)
J1-14	V1 (spare OP AMP)
J1-15	V2 (spare OP AMP)
J1-16	AGND

J2 (Port3 / Port2 / Port 0)

3 parallel ports (Port3, Port2 and Port0) are brought out to the connector J2. All these port pins are labeled on the silkscreen on the evaluation board.

J3 SPI/I²C Connector

J3 provides external connections for the SPI/I²C connector as described below.

Pin	Pin Name
J3-1	GND
J3-2	SS
J3-3	MISO
J3-4	MOSI/SDATA
J3-5	SCLOCK

J4 UART/RS232 Interface Connector

See “UART/RS232 Interface” in section 2.

J5 Emulation Connector

See “**Emulation Interface**” in section 2.

J6 Power Supply Connections

See “**Power Supply**” in section 2.

J7 Strokes

The ALE, PSEN and EA strobes are brought out to an external connector.

Pin	Function
J7-1	DGND
J7-2	ALE
J7-3	<i>PSEN</i>
J7-4	<i>EA</i>
J7-5	RESET

(4) LDR DEMONSTRATION CIRCUIT

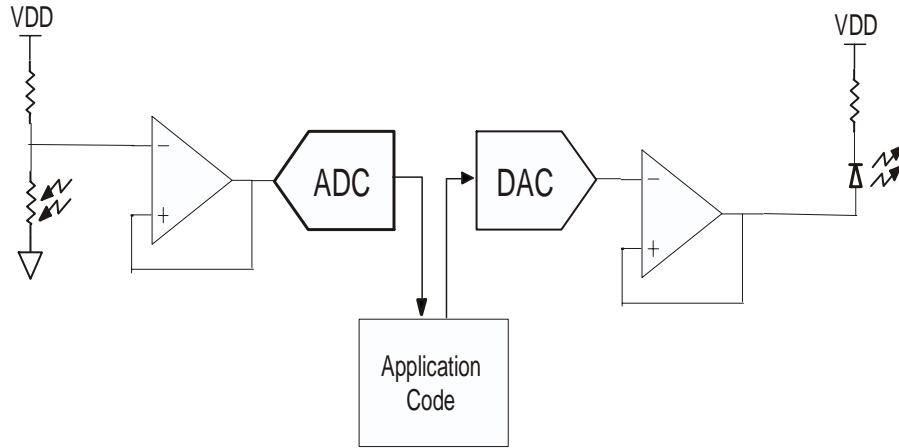

Using the sample code in `\code\adc\adcldr.asm` the variation in the resistance of the ldr can be seen by the reducing brightness of the output led as the amount of light is decreased

(6) ADuC8xx SAR EVALUATION BOARD PARTS LIST

Qty	RefDes	Part Description	Load Y/N	Supplier	Cat No
4	C1,C2,C3,C4	0.01uF SMD Multilayer Ceramic Cap, 0603 Case	ADuC812 ONLY	Farnell	431-590
4	C1,C2,C3,C4	0.1uF SMD Multilayer Ceramic Cap, 0603 Case	ADuC831/832 ONLY	Farnell	317-287
9	C7,C9,C11,C13,C19,C20,C21,C5,C6	0.1uF SMD Multilayer Ceramic Cap, 0603 Case	Y	Farnell	317-287
6	C8,C10,C12,C15,C16,C22	10uF 10V SMD Tantalum Cap, Taj-A Case	Y	Farnell	197-130
2	C17,C18	33pF SMD 0603 Case	ADuC812/831 ONLY	Farnell	498-555
1	C14	Regulator Input Cap (not used)	N		
3	D3 D4 D6	PRLL4002 SMD Diode (SOD-87 case)	Y	Farnell	316-2734
1	D1	Red SMD LED	Y	Farnell	515-607
1	D2	Green SMD LED	Y	Farnell	515-620
1	D5	Yellow SMD LED	Y	Farnell	515-619
3	R7,R14,R17	0R 0.063W 1% SMD Resistor, 0603 case	ADuC831/832 ONLY	Farnell	772-227
2	R8,R15	0R 0.063W 1% SMD Resistor, 0603 case	ADuC812 ONLY	Farnell	772-227
3	R9,R10,R22	0R 0.063W 1% SMD Resistor, 0603 case	Y	Farnell	772-227
1	R21	1.5R 0.063W 5% SMD Resistor, 0603 case	Y	Farnell	758-267
4	R1,R2,R3,R4	10R 0.1W 1% SMD Resistor, 0603 case	ADuC831/832 ONLY	Farnell	910-995
4	R1,R2,R3,R4	47R Surface Mount Resistor, 0603 Case	ADuC812 ONLY	Farnell	911-070
3	R13,R19,R20	560R 0.063W 1% SMD Resistor, 0603 case	Y	Farnell	911-203
1	R16, R18	1k 0.063W 1% SMD Resistor, 0603 case	ADuC812 ONLY	Farnell	911-239
5	R18, R24,R25,R26,R27,R6	1k 0.063W 1% SMD Resistor, 0603 case	Y	Farnell	911-239
1	R11	20k 0.063W 1% SMD Resistor, 0603 case	Y	Farnell	357-1555
1	R12	MPY54C569 Light Dependant Resistor	Y	Farnell	179-611
1	L1	Ferrite Bead (1206 case)	Y	Farnell	581-094
1	T1	Testpoint	N		
1	Y1	11.0592 MHz HC49/4HSMX case	ADuC812/831 ONLY	Farnell	263-734
1	Y2	32.768kHz Crystal	ADuC832 ONLY	Farnell	221-533
1	Q1	BC856 PNP Transistor	ADuC812 ONLY	Farnell	506-266
1	U1	ADuC831BCP	ADuC831 ONLY	ADI	
1	U8 (solder only two pins)	ADuC831BS	ADuC831 ONLY	ADI	
1	U1	ADuC832BCP	ADuC832 ONLY	ADI	
1	U8 (solder only two pins)	ADuC832BS	ADuC832 ONLY	ADI	
1	U1	ADuC812BCP	ADuC812 ONLY	ADI	
1	U8 (solder only two pins)	ADuC812BS	ADuC812 ONLY	ADI	
2	U4,U3	OP491GS Quad Single Supply Rail-to-Rail Op-amp	Y	ADI	
1	U5	ADM809RART	ADuC812 ONLY	ADI	
1	U6	MM74HC573MTC Fairchild Semi Octal D-Type Latch	N	Future Electronics	
1	U7	HY62256B LLT1-70 32k RAM TSSOP	N	Farnell	352-8509
1	U2	ZR78L05G , SOT-223, 200mA Regulator	Y	Farnell	572-329
3	SW1,SW2,SW3	Sealed 6mm SMD Push Button Switch	Y	Farnell	177-807
1	J1	16 Pin Straight Single Row Header	Y	Samtec (Sable Electronics)	TSM-116-01-T-SV
1	P1	Pair of 9V Snap on Battery Connectors	Y	Farnell	723-988
	J6	PCB Mounted Socket (2mm Pin Diameter)	Y	Samtec (Sable Electronics)	KLD-SMT2-0202-A
1	J5	5 Pin 90° Single Row Header	N		
1	J5	2 Pin Straight Header with friction lock	Y	Farnell	143-139
1	J4	4 Pin 90° Single Row Header	Y	Samtec (Sable Electronics)	TSM-104-02-T-SH
1	J2	26 Pin Straight Single Row Header	Y	Samtec (Sable Electronics)	TSM-126-01-T-SV
1	J3	5 Pin Straight Single Row Header	Y	Samtec (Sable Electronics)	TSM-105-01-T-SV
1	J7	5 Pin Straight Through Hole Header	N		
1	Each Corner	Stick on mounting feet	Y	Farnell	148-922