

## BROADBAND MODELLING OF INDOOR POWER-LINE CHANNELS

Francisco Javier Cañete, Luis Díez, José Antonio Cortés, José Tomás Entrambasaguas

**Abstract**-- The main purpose of this paper is to describe and model the characteristics of low voltage distribution lines inside consumer premises, when used as a broadband communication channel. Results from measurements performed both in the laboratory and in residential buildings, are presented and discussed. Also a channel model to simulate the behaviour of these lines for high bit-rate digital communications is proposed. The model contemplates the topology of the power grid and the characteristics of the wires and loads connected to them; it incorporates as well statistical time variation of the loads, so that the dynamic evolution of the channel performance can be evaluated.

**Index Terms**-- Power line communication, channel modelling, measurements, noise, time variation, OFDM.

### I. INTRODUCTION

IN the last years remarkable investigations in the field of power-line communications are being carried out, trying to upgrade preceding systems which were restricted to low data rates. For this purpose, international regulations that extends current limits in the available spectrum [1] are being developed. There are two main applications for power-line communication systems: to integrate them into wide area telecommunications networks as the access part (i.e. what is usually known as the 'last mile') [2], and to serve as local area networks (LAN's) inside buildings (small offices or homes). Our work is focused in the latter alternative, where the utilisation of the power grid present the valuable advantage, respect to other wired systems, that it is already installed in every place you want to use a communication terminal. For this service there are other competitor technologies like wireless LAN's, via radio or infrared. Its success will depend probably on the final cost of the required equipment.

Due to the fact that power lines were not conceived for communication purposes but to deliver electrical energy (what involve signals of much lower frequency and higher power), the medium characteristics are certainly adverse. The channel is time and frequency variant, and exhibits remarkable differences between locations, according to the network

This work was supported in part by the Spanish Ministry of "Ciencia y Tecnología" under CICYT Project No. TIC2000-1110.

The authors are with the Department of Ingeniería de Comunicaciones, University of Málaga, Málaga 29071 SPAIN (telephone: +34 952137121, e-mail: francis@ic.uma.es).

topology (often unknown), kind of wires installed and connected loads (of heterogeneous nature). Even in a specific power circuit the conditions change depending on the selected transmission path (i.e. sockets where the transmitter and receiver are plugged). These effects have been investigated on both the channel transfer function and existent noise for indoor networks [3,4,5].

In these channels the link is commonly established connecting the transmitter and receiver devices to the power grid, between the line and neutral conductors. They may be placed on the same or different phase, what in general increases the losses. However, the attenuation is usually very high, considering the short distances involved, because of the highly branched network and the absence of impedance matching.

This non traditional utilisation of the power lines requires the construction of adequate channel models, which have not been standardised yet. The multiple and quite different sources of disturbances and signal degradations that appear in these media, has lead to the definition of mathematical models extracted from campaigns of real measurements [6,7]. In our investigations another option closer to the physical nature of the lines is adopted [8,10].

The measurements carried out for this project are described in the following section, and some of the most representative ones are presented. Afterwards, the channel model is explained: including the representation of the network topology and loads, as well as the dynamics of the system. Several channel performance results obtained from simulations and measurements are compared in the fourth section. Finally, main conclusions are summarised in section V.

### II. MEASUREMENTS

Measurements of noise and channel transfer functions have been performed for different indoor power line channels for a threefold objective. At first, to explore the nature of the power grid when used to transmit signals in the medium frequency band (up to 30MHz, the usual limit for conducted emissions in EMC -electromagnetic compatibility- compliance tests), under various conditions and loads. Secondly, to provide data to construct the channel model, specially in the load characterisation part. And finally, to verify the channel responses that results from the simulations of the developed channel model.

In order to carry out the measurements, typical instrumentation for communications has been employed. To allow the interconnection of the equipment to the power wires, coupling circuits are required (essentially adequate high-pass filters and transformers to isolate them from the 230Vac signal). The set up comprises basically a network analyser to characterise the channel response and the loads, and spectrum analysers and digital storage oscilloscopes to register noise spectra and impulsive waveforms.

#### A. Channel frequency response

The electrical circuits exhibit an arborescent lay-out that influences remarkably the channel response, causing linear distortion of amplitude and phase. It depends on several factors: the characteristics of the main or direct path followed by the signal from transmitter to receiver, among which it is especially important the relative situation of the "branches" (i.e. additional wires that are tapered from the main path), and their lengths and loads. The distance of the link may be in fact, less important. It is common to find shorter links with higher attenuation level than longer ones. This is the case, for instance, when transmitter and receiver are not on the same electrical circuit, because the main path includes the distribution box, where all the circuits are connected, and power dispersion among them occurs.

To confirm these features, in fig.1 the attenuation of the frequency response for three measured channels in a residential building is plotted. The first exhibits low but not uniform attenuation despite the link was established over the same electrical circuit and the distance was quite short (no more than 5-6m.). The second line correspond to another arrangement over the same circuit but with more distance (about 20m), the attenuation registered is, obviously, higher, and more frequency variant. Finally, a result for a similar distance, but through different circuits is drafted, and it presents a worse behaviour.

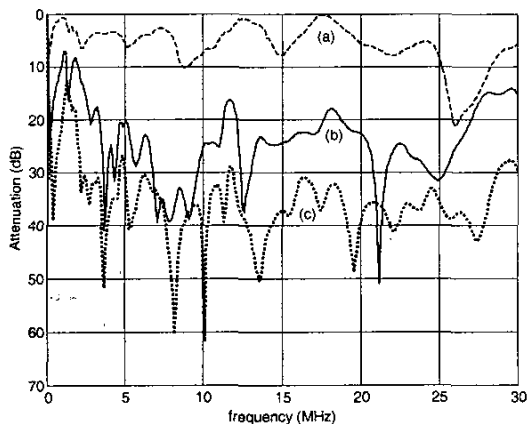

Fig. 1: Amplitude response for three measured channels in an apartment: a) through the same electrical circuit, b) with more transmission distance, c) through different circuits.

Phase distortion of the channel is mainly located around the notches [3,8], what could be solved, as usual, by means of linear equalisation techniques in the receiver circuit.

#### B. Noise

Noise power spectra have been also measured in different environments. The results usually (but not always) show a descending spectral power density as frequency increases. This fact suggests, along with the shapes of the frequency responses previously shown, that the system should avoid both the low frequency band and the amplitude notches (although the positions of these ones can not be predicted in advance). Another characteristic of the noise power spectral density (PSD), is its wide dynamic range, as seen in fig.2, where an example of the recorded data in the laboratory and in an apartment are depicted. The higher level presented in the first case is due to the higher number of electrical loads and interfering equipment, in contrast to the repose state at the apartment. That latter measurement can be representative of the usually quite low background noise at home in the absence of relevant devices working. However, the registered noise is drastically increased when certain appliances are plugged, as it will be discussed later. Some narrow band disturbances are also observed, possibly caused by radio interference in the HF band (e.g. citizen band, or from intermediate frequency stages of radio waves domestic devices, etc).

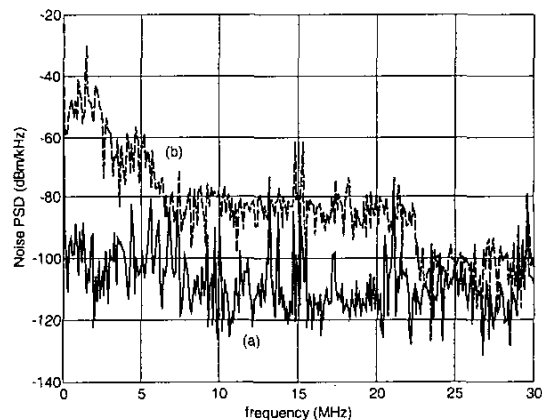

Fig. 2: Measurements of indoors background Noise PSD: a) in an apartment, b) in a university laboratory.

#### C. Loads characterisation

The characterisation of the loads is important because, on one hand, when they are connected to the previously mentioned branched lines affect considerably to the frequency response of the channel, and on the other hand, they will partially determine the level of existent noise. It is well known that the model of Additive White Gaussian Noise (AWGN) is not adequate for power-line channels [9], so a different proposal is presented in this work. We are going to assign part of the noise in the channel to the existing loads in the network (appliances basically), so they are considered as noise sources.

To this end, complex impedance values and emission of noise have been analysed as well, for a high number of appliances. To measure the generated noise, an additional circuit is necessary (similar to the so-called LISN -line impedance stabilisation network-, used in EMC tests), which allows the devices to be powered, but prevent the high frequency interference from the power grid to get into the measurement instrument.

In the measured loads it is observed, for instance, that the microwave oven and the light dimmer were among the noisiest ones, whose noise PSDs are reflected in fig.3 and fig.4. Other load that produces a medium level of noise would be the personal computer, the television set, or the refrigerator (also shown in fig.3), while the less noisy devices, in that broadband scenario, were incandescent lamps. This results are in good correspondence to other studies on the matter [5].

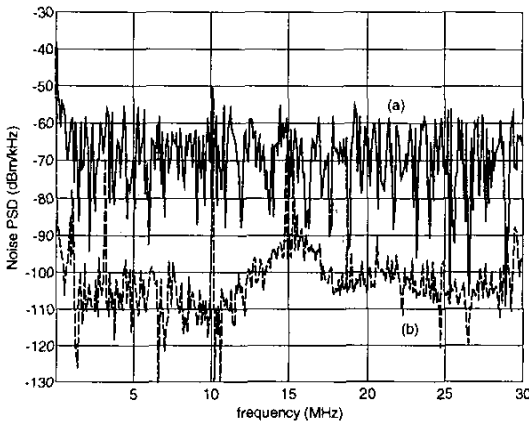

Fig. 3: Measurements of Noise PSD generated by some loads in working state: a) a microwave oven, b) a refrigerator.

Moreover, the status of the load, i.e. whether it is working or not, influences notably its level of generated noise as it could be expected. In fig. 4, this aspect is displayed for the light dimmer, and variations of more than 30dB at several frequencies appeared.

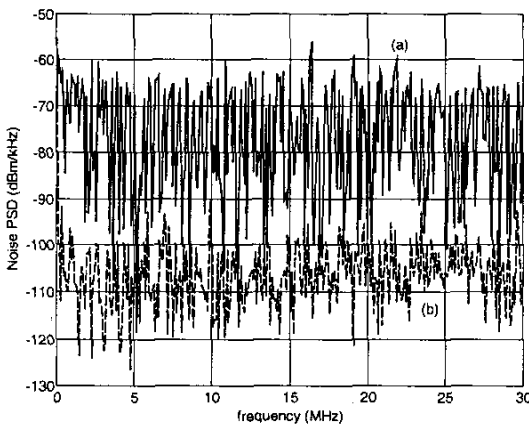

Fig. 4: Measurements of Noise PSD generated by a light dimmer, a) in working state, b) in repose.

Since, in most cases, the disturbance introduced in the channel by the appliances is nearly equally distributed along the frequencies in this range (up to 30MHz), average values in the band are included in table 1. It contains the mean and standard deviation values in the studied frequency band obtained from different loads, in order to get an approximated comparison of the level of noise generated by them (other ones that have been measured, provided insignificant values compared to the noise floor, like e.g. incandescent lamps).

TABLE I  
NOISE EMISSION LEVELS

	mean	std
vacuum cleaner	-66.2	6.0
microwave oven	-69.2	10.3
hair dryer	-72.0	8.2
light dimmer	-77.4	12.7
m.o. (oven mode)	-78.9	12.5
iron	-81.5	11.5
heater	-84.3	13.9
PC	-87.9	7.2
washing machine	-89.6	12.0
TV	-90.1	6.6
refrigerator	-102.5	9.4
oven	-104.2	10.8
toaster	-106.8	8.5

Statistical values (dBm in 1kHz) for some appliances.

In addition, some samples of impedance values, associated to these loads or possible noise sources, are plotted as well in fig. 5. It is observed that loads characteristics are quite diverse. They range from few ohms, under the mean characteristic impedance of the lines (of about 200Ω for typical wires), that determines the mismatch level at the discontinuities, up to kΩ. In many of them, the impedance values also change depending on the load status, e.g. the lamps. Anyhow, it is clear that some mismatch is unavoidable because they are quite frequency variant, and this will cause multiple signal reflections, and consequently multipath fading.

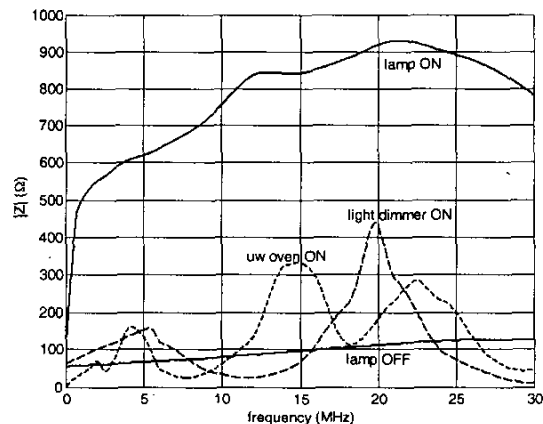

Fig. 5: Measurements of impedance values against frequency for several loads.

### III. CHANNEL MODEL

So far, some effort has been applied to achieve models for indoor power-line channels, but mostly with the formulation of parametric models to estimate the channel transfer function [6,7] and the expected noise [9]. Our work aim for a more physical approach, in which a high flexibility in the network topology layout and noise sources is adopted. Also, time variation of the channel is included, through the control of the load status.

The concept of the model is based on the consideration of the low voltage power grid inside buildings as a network of multiple connected transmission lines, terminated in loads of diverse nature. The channel has been supposed to have a linear response (available measurements at the moment indicate that non-linear components have a not very significant level). Although the propagation effects that signal experiments as it is conducted through the lines, lead to relevant linear distortion.

#### A. Network model

The considered model is based on the assumption that electric wires are a set of multiple transmission lines, interconnected to produce a tree-like network (see Fig.6). It has been developed to be quite versatile for designing the topology of the networks to study, and to allow a complete mobility of the transmitter and receiver, as well as the existing loads, among the different sockets.

The network layout is configured from estimations of the arrangement of real ones, which can be done either from plans (in case they were available, what is not common), or by simple inspection of the installation. This link to the structure of a real site, is only necessary at first instance, so that the model performance can be demonstrated by comparison with measurements carried out on the field. After that, the layout could be modified by extrapolating its parameters to other possible installations, changing lengths, connections, impedance values, etc. It would be also interesting to select them randomly in a range of values, defined from general characteristics of indoor power lines, and so to be instrumental in the statistical analysis of their behaviour.

The transmitter and receiver are coupled to the power grid, between neutral and line conductors (so, at first, only one phase is contemplated, restricting the model to apartments and medium or small-size houses), through corresponding impedance. These frequency variant impedance values are both obtained from measurements, of the output impedance for the transmitter part (signal generator plus coupling circuit), and the input impedance of the receiver part (coupling unit and signal analysers).

The network model has been programmed to contain many intersection nodes of different classes: a root node, that represents the connection box (the interface with the outside mains, and the point where all the electrical circuits are interconnected), intermediate nodes that represent junctions,

and terminal nodes, and they have associated a section of line. Each of these nodes is described by its type of wire, length, its ascendant and descendant nodes, and, if it is a terminal node, by the parameters of the load connected to it (that will be described in next paragraph). The basic transmission line that has been contemplated is a two parallel wires structure, whose parameters (characteristic impedance,  $Z_0$ , and propagation constant,  $\gamma$ ), have been taken from typical electrical cables data sheets used in real installations (diameters, materials, etc.). The length and relative position of the different sections should be estimated according to the layout.

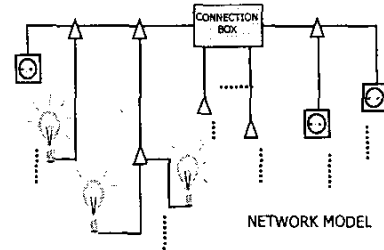

Fig. 6: Diagram of the model for the network topology.

The sockets, or terminal nodes, are assumed the access points to the channel where either transmitter or receiver equipment or loads can be located. The connected loads can be selected from a set of possible values of complex impedance, frequency and time variants, recorded from measurements of typical electrical appliances, as explained in the previous section. In this way, the arborescent nature of real power lines is approximated in a faithful way. Once the signal path has been set, the branches of the tree have to be collapsed, moving impedance through the lines, until a final equivalent transmission line is achieved, and that will determine the channel transfer function.

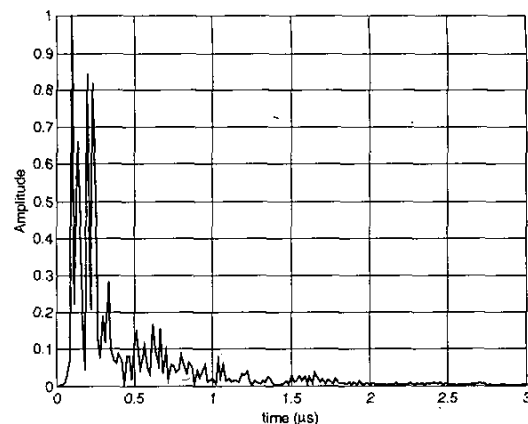

Fig. 7: Impulse response of modelled channel (normalised).

From real electric schemes of several residences, approximate models have been created for channel simulations. In fig.7, impulse response for a model designed from an apartment is shown (two sockets of the same electrical circuit in different rooms have been selected to form the link, and the distance could be 20m approximately). Echoes

appeared, due to the multiple reflections experimented by the signal as it travels through the network (because of wave propagation phenomena produced by impedance mismatch and branches). The shape of these responses is usually compared to the ones that appear in multipath channels like those of mobile radio [3]. In general, the more branched and loaded the network, the longer the impulse response.

An example of amplitude frequency response is drafted in fig.8, produced by the model for this apartment. According to the measurements, the generated transfer functions display some nulls in the amplitude responses at certain frequencies, which are in concordance with the impulse responses. Between them, there are bands with nearly flat response that could be combined for reliable transmission, although there is a high attenuation level present even in short-distance links.

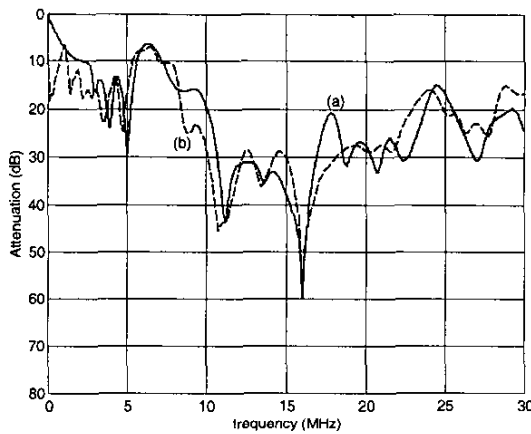

Fig. 8: Example of channel amplitude responses: a) obtained from the model, b) measured.

The model validity is studied contrasting its results with actual measurements, as seen in fig.8. It is not sensible to expect a perfect fit, since the model has been constructed without an exact knowledge of the layout. But certainly, the graphs of both the amplitude and phase responses [8], bear rather resemblance. Anyway, the final purpose of the model is not to match exactly with a certain channel configuration (which would not be very sensible due to the great sensitivity of channels respect to its eventual condition in the same premises), but to serve as a generator of feasible channel models.

**B. Time variant loads model**

Every device connected to the power grid represents a load to the network, whose model includes besides impedance values, associated noise sources. These frequency and time variant (depending on whether the device is in working state or not) values are obtained directly from measurements of typical electrical loads. As depicted in fig.9, in general, only two states would be necessary to describe the loads: active or not; but for some small appliances like hair-dryers, vacuum cleaners, etc., a three-state model would be needed: unplugged (out), plugged but not working (off) -because impedance

changes-, and active (on). Transitions between states are going to be controlled by digital signals on whose definition will depend the time variation of the channel.

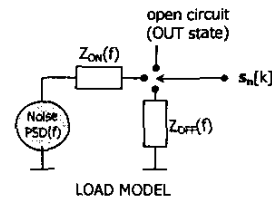

Fig.9: Diagram for the load model

Either of the measured loads can be introduced in the simulated network in any socket, and afterwards its contribution to the final channel will be calculated following the path towards the receiver (Fig.11). Their influence on the final received noise or channel transfer function is going to rely considerably on how close to the main signal path they are.

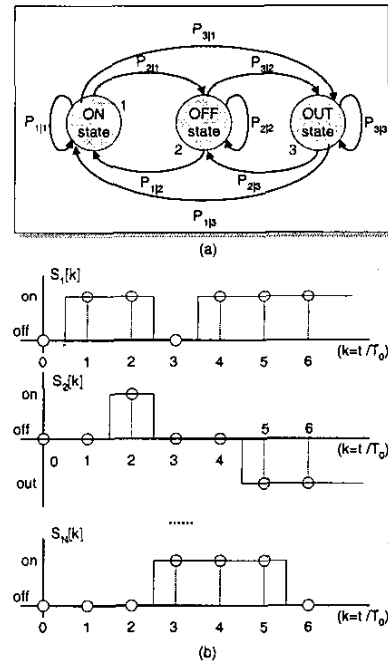

Fig. 10: Time variation modelling, a) state diagram of the loads; b) examples of possible states variation of loads.

Clearly, the channel conditions change through the course of the day, when appliances are switched on and off. However, those variations are going to be quite infrequent respect to the bit rate used in the communication channel. So the channel evolution can be seen as successive transitions of stationary states, which correspond to a certain channel transfer function and equivalent noise. These events are contemplated in the model by changing the impedance and noise values of the loads plugged in the sockets in a statistical way. A simple strategy is to study the state changes using discrete-time sequences generated from discrete sources with memory. For this purpose Markov models seem to be quite suitable (fig.

10). The transition probabilities can be estimated from assumptions based on common behaviour at homes, which are going to vary drastically according to the period of the day under study. For instance, the probability of remaining turned on for a television set (or a heater...) once it is operating is quite higher than the probability of change to the off state (assuming a time basis of the order of minutes). Opposite could be the case of a cordless phone or a microwave.

### C. Complete Model

Once the topology of the power-line network has been modelled, the transmitter and receiver locations are selected in order to define the link. Then the channel responses for the signal path and for the different noise sources (which are clearly distinct) are calculated, and added to obtain the complete channel model as depicted in fig. 11. In this approach, the superposition principle is being assumed, because the channel is supposed linear with respect to the signal and noise sources. In this manner, the channel response and total noise at receiver can be calculated.

Furthermore, a background noise, recorded measuring the power grid when no appliances were active in the proximity, is added to create the noise model. Apart from that, a narrow-band interference model could be aggregated for completeness. Although, to some extent, these contributions have been taken into account in an indirect way, because some ingress of radio interference was present during the measurement procedure of the noise sources, and they are not avoided even despite the averaging (that is why some spikes appear in the noise PSD). Given that nature of this narrow-band interference is mainly radiation, our model for this channel based on conducted signals would not be appropriate. So a parametric technique would be needed, like the superposition of independent pass band signals in which the central frequency, phase and amplitude (the latter two can be modulated randomly) have to be defined [9].

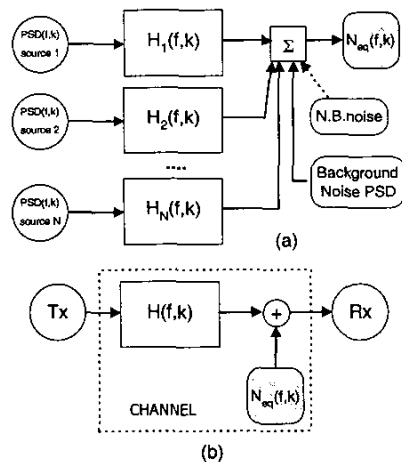

Fig. 11: The complete time-variant model. a) noise generation model; b) equivalent channel model.

As discussed in the previous section, the channel is going to be time variant, considering a discrete time ( $k$ ), which resolution should be high enough to follow the asynchronous transitions between stationary states of the loads. However, a very short time slot may not produce more accurate results, due to the slow variation of physical changes in real power-line environment. In order to simulate the channel behaviour during a period of time, outcomes from the random variables that model the loads are obtained, and then the channel response and noise is only computed for the different configurations or network states previously calculated. Once these channel responses and equivalent noises are available, they are saved and could be used, e.g., to get simple filter models adequate for channel emulation.

### D. Model Results

The objective of the presented channel model is to provide a way to study the behaviour of typical power lines for different indoor configurations. The input parameters for the simulator, basically network topology, can be estimated either from some physical knowledge of the layout, the wires installed or kind of existing loads in a real one, or in a random way, to get averaged performances.

The plot in fig 12 displays the amplitude of the channel frequency response obtained by simulation of the power line of an apartment of about 80m<sup>2</sup>, where the path between transmitter and receiver should not exceed 35-40m in most cases. The power grid contains four different electrical circuits, modelled with more than 50 nodes, or line sections interconnected, also ten loads among all in the network were considered dynamic in the analysed period.

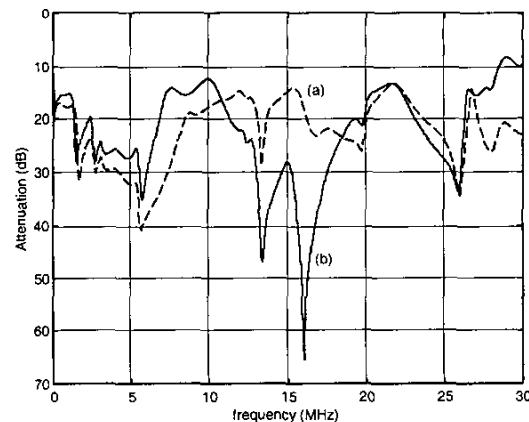

Fig. 12: Simulated channel attenuation for two cases: a) with the connection of a light dimmer near receiver, b) without this load.

Relative changes in network topology have a strong influence on the channel response. For instance, it is remarkable the effect produced by the connection of a load (a light dimmer) some metres apart from the receiver. It smoothes the frequency response (because a medium value of impedance is put where there was an open circuit, with a high reflection

coefficient that causes ‘notches’) (fig.12), but enhances the noise level (fig. 13). From a communication system point of view, the frequency band between 15 and 18MHz could be useful or not depending on the load connection status. The location of transmitter and receiver is also very important, because differences of more than 30dB of attenuation in some frequency bands are not strange, even in the same house.

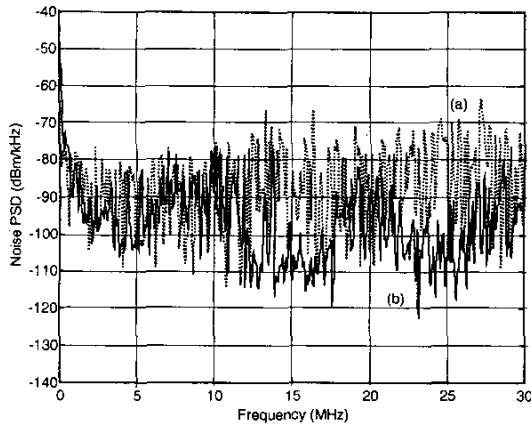

Fig. 13: Noise PSD at receiver: a) when a light dimmer is active nearby, and b) when it is not.

Time variation of another possible link among those simulated for this network, is evaluated during two hours of ‘real time’ in a period of the day with high human activity (e.g. early in the morning or evening time). To define the probabilities for state diagrams of the loads, a mean transition time of 5 minutes and practical considerations (for instance it may be less likely for a microwave oven to remain in working state after this period, than to change to off-state), have been considered. In fig 14, it is shown the evolution of the amplitude frequency response of the channel response between 7 and 15MHz. In this case, variations of 15dB are observed for certain frequencies, which must be produced by load changes, while others notches remains at the same frequency, maybe due to some socket with nothing plugged in.

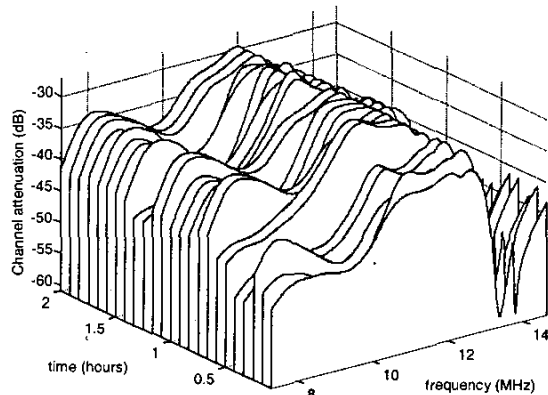

Fig. 14: Simulated channel evolution over a period of two hours, for a selected frequency band.

Clearly, the results obtained by the model must not be expected to match perfectly with the ones that could have the real network, because there are several approximations made in the modelling procedure. Some of them are: linearity assumption, adoption of transmission lines model, uncertainty in the wires layout, or in the measured noise and load characteristics, or load transitions probability estimation. Actually this mismatch between real channel responses and the simulated ones was verified by means of some measurements, as discussed before. However, these validation tests have revealed that model results are in good correlation with measured channels, at least in terms of mean attenuation in the whole band, its grade of variation, averaged received noise, and hence channel capacity (which may be the more important parameter, provided that an adaptive transmission technique is employed). Main discrepancies appear in the exact frequencies of ‘notches’ and spikes. Therefore, it can be concluded that this tool can supply realistic power-line channels.

One of the remaining tasks would be to study further the transitions between these stationary states, when some impulse noise is presumed to arise, though these unfavourable situations can be solved with adequate channel coding techniques.

#### IV. CHANNEL PERFORMANCE EVALUATION

Channel capacity is the upper bound in digital transmission. Therefore, an estimation of the spectral efficiency (b/s/Hz) attainable in these channels will provide, not only information about their feasibility as high bit-rate channel, but also a mean for comparison with other communication media. In this section this parameter is used to contrast the measurements results to the ones provided by the model.

The Shannon theorem has been applied to calculate the maximum ideal capacity, along with a more practical approach, the Orthogonal Frequency Division Multiplexing (OFDM) technique, also known as Discrete Multitone (DMT) when referred to wired systems. OFDM is a very suitable scheme for spectrally shaped channels. It is based on partitioning the data rate before modulating digitally (in general with quadrature amplitude modulation -QAM-) several carriers in narrow subbands (in which the channel characteristics can be considered uniform), and then they are summed to create an OFDM symbol. In order to avoid intersymbol interference at the receiver end, some redundancy in terms of a cyclic prefix should be added, whose length depends on the channel impulse response duration [11,12].

The real scenario and its corresponding modelled channel, whose responses were depicted in fig. 8, along with quite noisy conditions (like in fig. 3a), have been chosen to illustrate the model performance. This will also give an idea of the power line channel capability for broadband communication purposes. For the simulation, a flat PSD of  $-20\text{dBm/kHz}$  has been adopted for the signal launched into the power grid by

the transmitter. (It represents a not excessive value, but higher than allowed by current regulations [13], and has been used as a design criterion for modem manufacturing companies in this area.) After considering multiple scenarios, it has been found that 512 carriers and a number of samples for the cyclic prefix equivalent to the 15% of the total OFDM symbol length, are convenient numbers for these power-line channels. These figures have been estimated based on a trade-off between maximum bit rate and implementation complexity for a real system. Binary PSK and square QAM constellations with an error probability of  $10^{-6}$  has been assumed for the calculations.

Simulations results obtained with these settings are shown in fig. 15 and fig. 16. Although there is no perfect matching for the ideal spectral efficiency, averaged values are very similar: 6 b/s/Hz for the modelled channel and 6.3 b/s/Hz for the measured one. When a practical modulation, as OFDM, is used, these quantities reduce to 2.6 b/s/Hz and 2.8 b/s/Hz, respectively, and also the achievable spectral efficiencies are more akin. This resemblance is of special interest in the frequency band from 10 MHz to 17 MHz where, as expected from fig. 8, unfavourable conditions for transmission exist, and for the 5 MHz to 10 MHz band, in which high number of bits per carrier can be used (what reinforces that the model fits adequately both amplitude and phase responses).

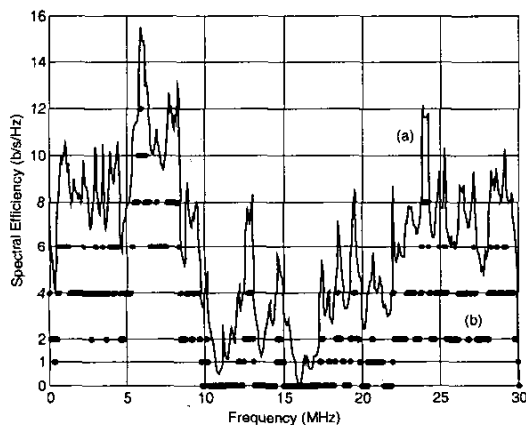

Fig. 15: Spectral efficiency estimation for the measured channel response of fig. 8: a) Shannon Limit, and b) with OFDM.

In reference to the attainable bit-rate, 72 Mb/s are estimated for the measured channel and 67 Mb/s for the modelled one, what represents about 7% of difference.

Apart from its utility to compare the channel model performance, the above results also show that power lines are a feasible medium for supporting high bit-rate applications. The differences in the noise PSD or channel frequency response that may occur during the communication, can be solved by changing the distribution of bits per carrier dynamically. With this procedure, whenever important changes take place, bits are added or subtracted from carriers according to its actual signal to noise and distortion ratio.

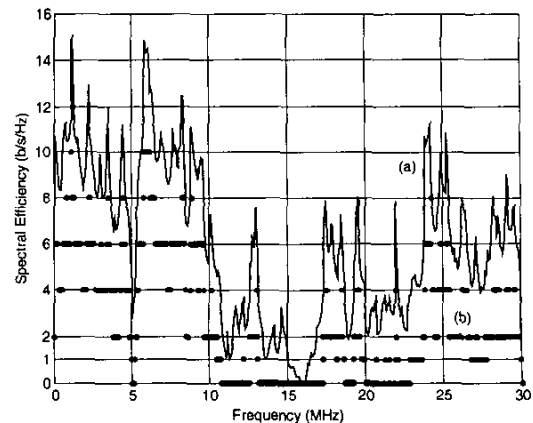

Fig. 16: Spectral efficiency estimation for the modelled channel response of fig. 8: a) Shannon Limit, and b) with OFDM.

## V. CONCLUSIONS

A quite complete model, and adjusted to the nature of indoor power-line channels, has been proposed. It contemplates the network topology, by considering the power grid inside buildings as the interconnection of multiple transmission lines, terminated in loads of diverse characteristics of impedance and generated noise. Time variation is also incorporated by means of statistical changes in the loads state, so that the dynamics of the channel can be predicted.

It can provide feasible channel responses in an easy way, and it is scalable and adaptable to many kinds of structures of electrical networks, without the necessity of carrying out measurements on the field for each one. This model allows to study the evolution of the channel performance during the day, so that later analysis can be made of e.g. worst conditions of disturbances, average capacity, or minimum throughput attainable. All this information can be used to evaluate the ability of different transmission techniques, receiver structures and algorithms to cope with the channel conditions and changes.

In the channel capacity analysis here presented, theoretical limits and more practical schemes (adoption of OFDM) have been considered, demonstrating that transmission at tens of Mb/s could be feasible. This would permit the use of the indoor power lines as a good medium for new emerging services, like home LANs, common access to external telecommunication networks, advanced home automation applications, etc. In fact, different companies are carrying out measurements with modem prototypes that confirm these conclusions. However, this capacity may change seriously with time, due to the connection and disconnection of the noise sources (electrical devices mainly), what leads to think about the application of an adaptive transmission technique, for example variable rate OFDM.



## REFERENCES

- [1] EN 50065, "Signalling on low-voltage electrical installations in the frequency range 3 kHz to 148.5 kHz". CENELEC, 1991.
- [2] Hooijen, O.G. "Aspects of Residential Power Line Communications". Shaker Verlag, Aachen, 1998.
- [3] Philipps, H. "Performance measurements of power line channels at high frequencies". Proceedings of the 1998 International Symposium on Power-Line Communications and its Applications (ISPLCA), Tokyo, Japan, pp. 229-237.
- [4] Cañete, F.J.; Díez, L.; Entrambasaguas, J. T. "Analysis of residential indoor power lines as a communication medium". Proceedings of the fifth Workshop on Emerging Technologies in Telecommunications, Baiona, Spain, pp. 202-206, Sep 1999.
- [5] Liu, D. et al. "Wide Band AC Power Line Characterization". IEEE Trans. on Consumer Electronics, vol.45, n°4, Nov. 1999.
- [6] Philipps, H. "Modelling of power line communication channels". Proceedings of the third International Symposium on Power-Line Communications and its Applications (ISPLC'99), Lancaster UK, pp. 14-21.
- [7] Zimmermann, M.; Dostert, K. "A Multi-Path Signal Propagation Model for the Power Line Channel in the High Frequency Range". Proceedings of the third International Symposium on Power-Line Communications and its Applications (ISPLC'99), Lancaster UK, pp. 45-51.
- [8] Cañete, F.J.; Díez, L.; Entrambasaguas, J. T. "Indoor Power-Line Communications: Modelling and Measurements". Proceedings of the fourth International Symposium on Power-Line Communications and its Applications (ISPLC'2000), Limerick, Ireland, pp. 117-122.
- [9] Zimmermann, M.; Dostert, K. "An Analysis of the Broadband Noise Scenario in Powerline Networks". Proceedings of the fourth International Symposium on Power-Line Communications and its Applications (ISPLC'2000), Limerick, Ireland, pp. 131-138.
- [10] Cañete, F.J.; Díez, L.; Entrambasaguas, J. T. "A Time Variant Model for Indoor Power-Line Channels". Proceedings of the fifth International Symposium on Power-Line Communications and its Applications (ISPLC'2001), Malmö, Sweden, pp. 85-90.
- [11] Bingham J.A.C. "Multicarrier modulation for data transmission: an idea whose time has come", IEEE Communications Magazine, Volume: 28 Issue: 5, May 1990, pp. 5-14.
- [12] Chow, J.S.; Tu, J.C.; Cioffi, J.M. "A Discrete Multitone Transceiver System for HDSL Applications". IEEE Journal on Selected Areas in Communications, Volume: 9 Issue: 6, Aug. 1991, pp. 895-908.
- [13] EN 55022, "Limits and methods of measurement of radio disturbance characteristics of information technology equipment", CENELEC 1994.



**Francisco Javier Cañete Corripio** was born in Málaga, Spain, in March 1972. He received the M.S. degree in telecommunication engineering in 1996 from the University of Málaga. In 1997 he joined the Communication Engineering Department, University of Málaga, where he is currently working toward the Ph.D. degree. From 2000 he also collaborates in the *Nokia SCT* in Málaga.

His research interests include mobile and digital communications and channel modelling, mainly focused on high-speed transmission through power lines.



**Luis Díez del Río** received the M.S. and Ph.D. degrees from the Polytechnic University of Madrid, Spain, in 1989 and 1995, respectively, both in telecommunications engineering.

From 1987 to 1994 he was with the Department of Signals, Systems and Radiocommunication, Polytechnic University of Madrid. In 1994 he joined *Fujitsu-España R&D* center, where he worked in the development of modems. Since 1997 he has been with the Communication Engineering

Department, University of Málaga. His research interests include digital communication, a field in which he has worked for many years. His experience includes most of its applications, i.e., voiceband, DSL and cable modems, satellite, mobile, and power line communications, etc., as well as technical aspects, i.e., synchronization, adaptive signal processing, modulation, coding and multiple access.



**José Antonio Cortés Arrabal** was born in Málaga, Spain, in November 1974. He received the M.S. degree in telecommunication engineering from the University of Málaga in 1998. In 1999 he joined the Communication Engineering Department, University of Málaga, where he is currently working toward the Ph.D. degree. From 2000 he also collaborates in the *Nokia SCT* in Málaga.

His research interests include mobile communications and digital communications, the latter mainly focused on high-speed transmission techniques for power line communications.



**José Tomás Entrambasaguas Muñoz** received the M.S. and Ph.D. degrees, in 1975 and 1990, respectively, both from the Polytechnic University of Madrid, Spain.

From 1975 to 1978, he worked at the Polytechnic University of Madrid. In 1978 he joined *Fujitsu-España R&D* center, where he worked in the development of packet switching systems for data networks (in collaboration with *Telefónica de España*), data transmission systems, and computer local area networks. In 1993, he joined the University of Málaga at the Communication Engineering Department, where his current interests include digital signal processing techniques applied to digital communication and methodologies for efficient and integrated development of complex communications systems.